

SALES DRAWING SALES DRAWING

SALES DRAWING SALES DRAWING

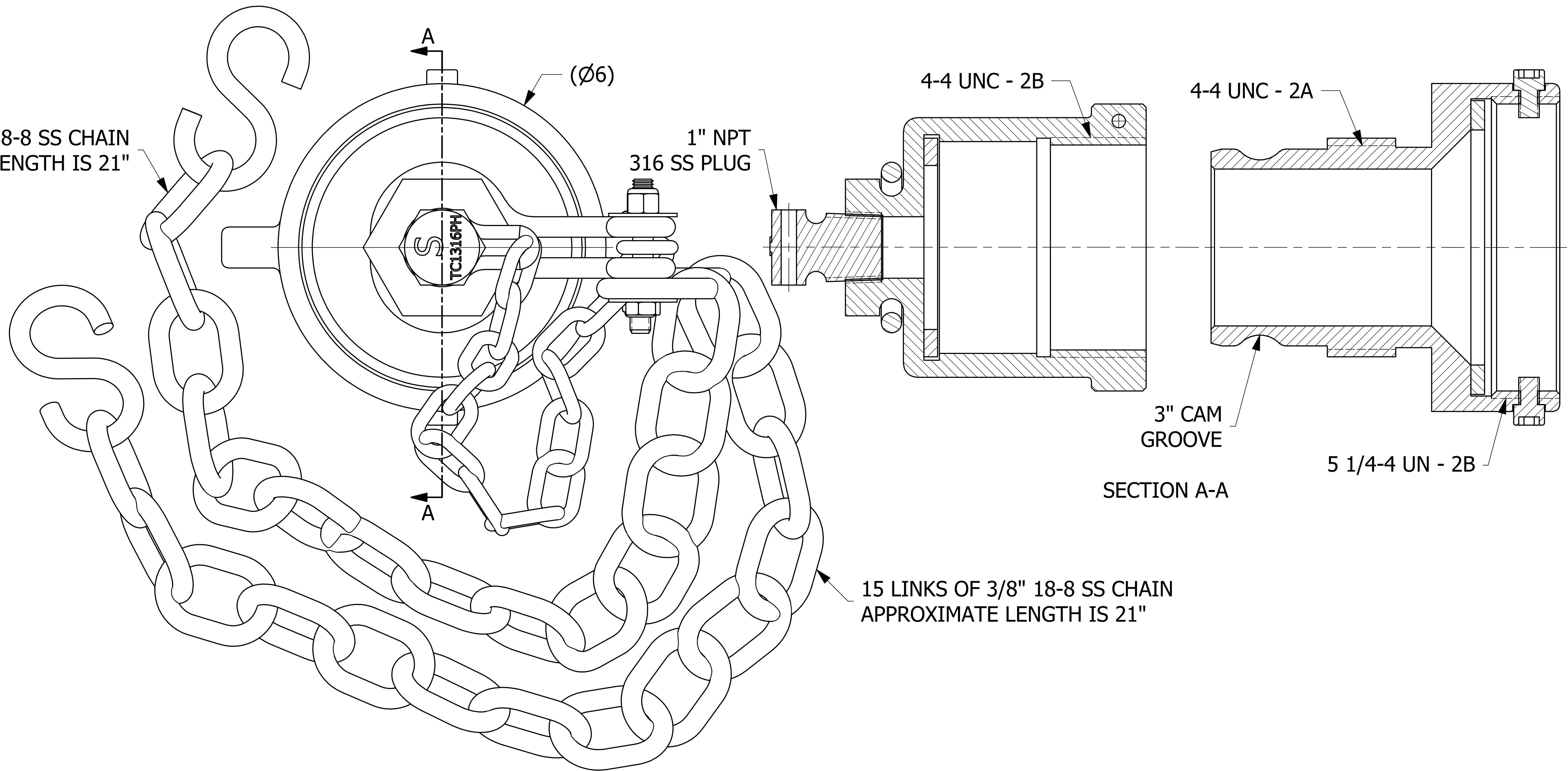

NOTES:

1. UNLOADING ASSEMBLY IS DOT AND AAR APPROVED.
2. AAR APPROVAL # IS E-149523.
3. SET SCREWS SECURE ADAPTER WHEN CAP IS REMOVED.
4. APPROXIMATE HEIGHT IS 9 1/2".
5. GASKET MATERIAL IS BLACK VITON A.
6. CAP MATERIAL: 416 SS.
7. ADAPTER MATERIAL: 316 SS.
8. 5 1/4-4 UN - 2B THREADS CONFORM TO FIGURE E18 OF THE AAR TANK CAR MANUAL.

B	RJP	5-11-16	UPDATED TE3S416DC6A GEOMETRY, AAR APPROVAL # WAS E-049013, UPDATED TITLEBLOCK
A	RJP	12-19-13	RELEASED FOR PRODUCTION
REV	BY	DATE	DESCRIPTION

<small>UNLESS OTHERWISE SPECIFIED DIMENSIONAL TOLERANCES</small> FRACTIONAL: ±1/16 X.XX: ±.03 X.XXX: ±.015 ANGULAR: ±1° DEBURR ALL SHARP EDGES. ALL MACHINED SURFACES TO HAVE A 125 RMS FINISH UNLESS NOTED OTHERWISE. THIRD ANGLE PROJECTION	DRAWN BY:	RJP
	CHECKED BY:	JRO
	PROTOTYPE BY:	RJP
	PROTOTYPE DATE:	12/11/2013
	APPROVED FOR PRODUCTION BY:	JRO
	PRODUCTION DATE:	12/19/2013

SALCO PRODUCTS, INC.		
QUICK CONNECT 3" THREAD ON		
MATERIAL: SEE NOTES		
PROJECT #:	090219	SHEET #: 1 OF 1
DRAWING #:	D37959	SCALE: 1:1
PART #:	TE3S416SU6A	